



ROCK-FORD A's MANIFOLD NEWS

P.O. Box 4001, Rockford, IL 61110
Region of MARC – Chapter of MAFCA
<http://rockfordas.modela.club.googlepages.com/>



August, 2012

OFFICERS

President

Bill Aupperle
(815) 397-4059
wgaupperle@comcast.net

Vice President

Dwain Plymale
(815) 968-5387
jdplymale@sbcglobal.net

Treasurer

Jim Morley
(815) 979-6980
jsmorley@hotmail.com

POSITIONS

Newsletter/Resource Library

Chris Aupperle
(815) 397-4059
aupps31ford@comcast.net

Tools

Ron Ortberg
(815) 399-6092

Wedding Coordinator

Alice Whitney
(815) 895-5023

Social Concerns

Nan Stewart
(815) 885-3467

Photographer/Historian

Kathy Forbes
(815) 218-0147

Era Fashions

Nan Stewart
(815) 885-3467

Hats, Shirts, Jackets

Wendell Anderson
(815) 234-8412

Club Vests

Kathy Forbes
(815) 218-0147

Webmaster

Dave Clark
(815) 389-4316
modela@aol.com
modela_coupe@charter.net

Tour Coordinator

Russ Kothe
(815) 871-6169

MONTHLY MEETINGS

7:00 pm fourth Tuesday
Central Christian Church
6595 Guilford Road
Rockford, IL 61107

Calendar of Events

*Annual Club Picnic instead of monthly meeting
No monthly meeting on Tuesday, August 28!*

Saturday

August 4, 2012 11:00
1:00 – 4:00 p.m.

Brunch at Stockhom Inn Restaurant

Model A Day at the Conservatory
*Nicholas Gardens, Rockford
They are encouraging us to dress vintage! Each car displayed gets 2 free tickets to the Conservatory – a \$12.00 value!*

Sunday

August 5, 2012 – 8:00 to 5:00 p.m.

22nd Annual
Vintage Transport Extravaganza at the
Illinois Railway Museum
*Union, Illinois
Send in the registration form & \$5.00 to ride the trains & buses all day! Bring a picnic lunch!*

Sunday

August 12, 2012 – Noon

Annual Club Picnic
*Warren Paulson's Farm – Argyle, Illinois
Bring a dish to pass. Beverage, brats & burgers, tableware will be provided.*

Saturday

August 18, 2012

4th Annual Model A Day
Amana, Iowa

Sunday

September 9, 2012 – 11:00 parade
begins

Roscoe Lions Fall Festival Parade
Roscoe, Illinois

Sunday

September 9, 2012 – 11:00 to 4:00

Beckman Mill Heritage Sunday
Beloit, Wisconsin

Saturday

September 15, 2012 – 7:00 a.m. meet
at Jessica's Restaurant in Roscoe, IL

Hill & Valley Antique Auto & Americana Show
*Cross Plains, Wisconsin
\$10 registration; contact Chris Aupperle for a registration form*

Saturday

September 22, 2012



International Model A Day with the
Great Lakes A's
*Yerkes Observatory in Williams Bay, WI
1:00 lunch at Sprecher's Restaurant, Lake Geneva, WI*

Sunday

September 23, 2012

Stillman Valley Fall Festival Parade
*Stillman Valley, Illinois
Dessert afterwards at Dave & Sara Werckle's home*

Tuesday

September 25, 2012 7:00 p.m.

Monthly Meeting

Saturday & Sunday
October 6 - 7, 2012

Fall Tour
Milwaukee, Wisconsin area

*Have you told your friends about the Rock-Ford A's?
Car ownership is not necessary – just come along for the fun!*

1. Welcome – 40 in attendance today!
2. Thanks to Larry Ethun for bringing cookies tonight!
3. Welcome visitors: Frank McReynolds, Cody Steele, Nichole Wagner
4. Cars for sale: contact Bob Poggense and Bill Aupperle who has info. from a seller in Wisconsin.
5. Parades: Mt. Morris = 11 cars, \$110; ByronFest = 9 cars, \$85;
7. Breakfast Club continues – thank you John Hausen!
8. Scheduled events (see front page): Model A Day at Nicholas Conservatory; Vintage Transport event at IRRM; Beckman Mill Heritage Day; annual Club picnic August 12; Model A Day in Amana, Iowa; Tour with Great Lakes A's on Int'l Model A Day in Sept.; Roscoe and Stillman Valley parades not yet confirmed; Ill. Region MAR & MAFA Model A & T Swap Meet; Hill & Valley Show; Fall Tour details yet to come.
9. Tonight's Tech-Talks courtesy of Tim Stolberg and Bob Bellard – thank you!
10. Tonight's Lady A's Chat courtesy of Chris Aupperle with Pauline Lawhorn, Alikce Whitney and Linda Clark
11. Treasurer's Report as of 5/22/12, submitted by Jim Morley, Treasurer

Checkbook balance as of 6/24/12	\$ 4872.85
Cash on hand	<u>15.00</u>
Total balance	\$ 4887.85

Expenses = Chris Aupperle	
newsletter expenses	<u>28.69</u>
Total Expenses	\$ 28.69

Income = Dues	15.00
Coffee Donations	6.00
Mt. Morris Parade	<u>85.00</u>
Total Income	\$ 106.00

Checkbook balance on 7/24/12	\$4944.16
Cash on hand	<u>21.00</u>
Total balance on 7/24/12	\$4965.16

Glimpse from the Gavel

Bill Aupperle, Director



Thank you Tim Stolberg for your presentation Tuesday night. I know we will build on this information, so we can start trouble shooting our car electrical problems. The Club has voted to add/replace these tools to our Tool Inventory: 1) Kingpin reamer, 2) Break centering tool, 3) Brake lining riveting tool, 4) Fly wheel gauge, 5) Carburetor float gauge, 6) Infra-red temperature measuring tool, 7) Light switch spider c-clip insertion and 8) a Rock-Ford A's brick for the Gilmore Museum. Thank you members.

Drive carefully

Editor's Extras

Chris Aupperle, Editor



Everybody has a story about their car adventures, repairs, history. Share yours, so we can all enjoy the many aspects of this car hobby. Make this newsletter even better with YOUR story!

Please contact me if you are not getting your newsletter via email or postal delivery – keep in touch!

Member's Corner: Model A Tip

Contributed by Bob Bellard

This week my starter acted as though it was dead, not even a click. All the lights and horn worked. I charged the battery just in case but it wasn't dead. I tried rocking the car in gear thinking the Bendix was stuck--nothing.

I tried handcranking no avail. I took out the starter motor and noticed the shaft and Bendix was bone dry but very clean. I took it to Ed Trap in Beloit and he spun tested it and was perfect. I have an fuse on my starter switch which was OK. So I took apart the starter switch cleaned it and cleaned all the screws and terminals on the fuse box. Then used alot of light weight machine oil on the Bendix and shaft. It popped right off first time. Might have been both or either---can't tell. The fuse receptical might have been oxidized or Bendix hung up ? Works fine. Make sure you use lite oil not grease on Bendix shaft. There should be a felt washer-oiler on the shaft, some are gone.

Tech-Tip

Building on the key information provided by Tim Stolberg's presentation Tuesday, I'm including a diagram for points we will be measuring voltages and resistances. This is to show where our electrical discussions are heading. As Tim said, there is a lot more to come' there is a lot to be learned about the Model A electrical system. **But, the rewards will be great.**

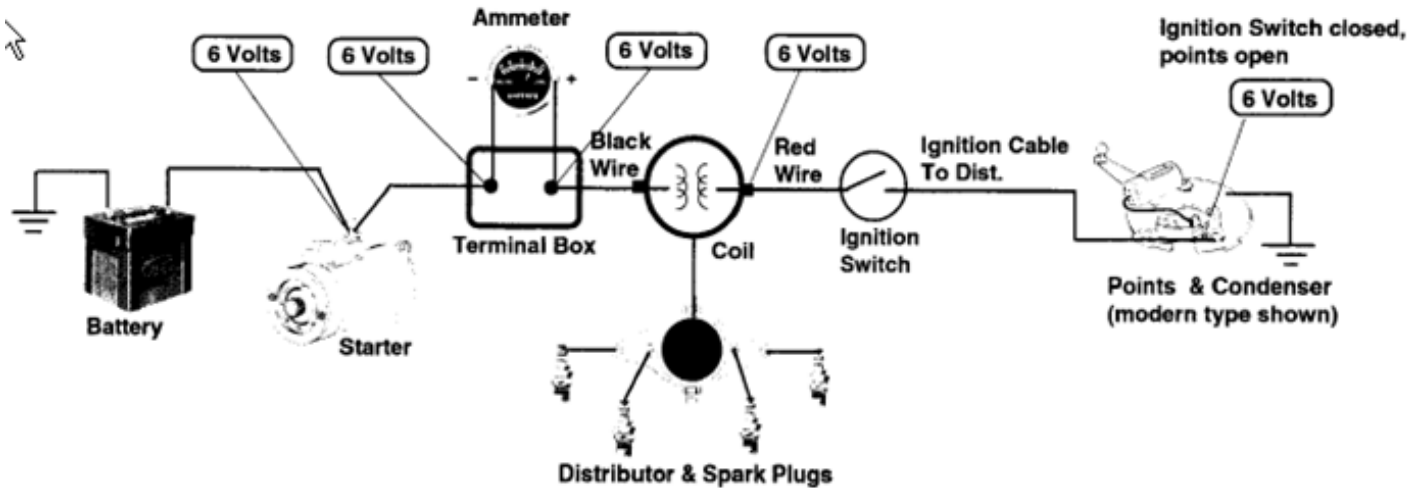

Ignition System Schematic

This is just the ignition system. There'll be more diagrams as we work our way through all these wires - the horn, lights & turn signals, engine starter, generator and charging diagrams. Lots of fun.

Fashion Fun - Era Purses

The term 'handbag' first came in to use at the beginning of the twentieth century and was used for leather bags then carried by men. It was the 1920's that saw the first emergence of the modern handbag carried by women. This was another period with a fashion for light, skimpier dresses that weren't suited to pockets. It was also a period of growing independence for women, when women could go out on their own and travel without a man or a servant to carry things for them. The handbag was at once a **fashion accessory** chosen to match an outfit and a practical symbol of their new independence, women could now go forth into the world carrying all they needed themselves, self-reliant and fearless.

<http://www.gleni.it/bag-in-history.html>

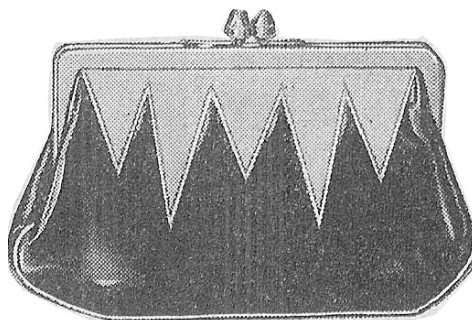

Welcome New Members to the Club

Don't forget that you don't need to own a Model A; enjoying friends is the most important aspect of this hobby!

PAST EVENTS



Members enjoy waiting before the Mt. Morris parade



The Byron parade was hot and slow, but it was nice to cool down with snacks afterwards at Wendell & Sharon Anderson's house.



Cruise Night at Winds & Wheels Museum, Poplar Grove, IL



Linda Clark shares her expertise about era kitchens.



MODEL "A" RESTORERS CLUB

6721 Meriman, Garden City, Michigan 48135

Membership Dues: Regular Mail: U.S. \$38;

Air Mail: U.S./Canada \$50, International \$56 for the calendar year.

Includes 6 issues of Model "A" News over a calendar year

Name (Print) _____

Spouse's Name _____

Address _____

City _____ State _____ ZIP _____

Phone Number _____

Is it ok to list phone number in club roster (yes or no)? _____

Signature _____

EMAIL address _____

Is it ok to list email address in club roster (yes or no)? _____

Circle one: Check | Visa | MasterCard | Discover Card

Card Number _____

EXP. Date _____ last 3 digit code on back of credit card: _____

Free Membership Program

As you may know, MAFCA is offering a year's free membership to Model A enthusiasts who are not MAFCA members. This program has been met with excitement throughout the world and so far has been very successful in introducing MAFCA to new members. But, there is some small confusion. This is being offered to people who have not been MAFCA members before. It is designed to encourage people interested in the Model A hobby to join our family. It is not meant to be used for renewals. The Board of Directors encourages the chapters to continue to provide these free applications to prospective members.

Invitation To Join Model A Ford Club of America

New Membership

Name _____

Spouse's Name _____

Address _____

City _____

State _____ Zip _____

Country _____ Telephone _____

Permission to publish my telephone number in future Membership Posters? Yes: _____ No: _____

Gift Membership

Name _____

Spouse's Name _____

Address _____

City _____

State _____ Zip _____

Country _____ Telephone _____

Permission to publish my telephone number in future Membership Posters? Yes: _____ No: _____

~ Membership Benefits ~

The Restorer magazine • Technical Support • Local Chapters • National Meets • Era Fashion Guidelines • "How To Restore" Series • Judging Standards and Restoration Guidelines

Dues per year are
U.S. Membership - \$40
International Membership - \$50
International First Class - \$56

Make checks or money orders payable to
MAFCA
U.S. Funds Only

For Credit Card Orders ~ Visa / MasterCard (circle one)

Card Number: _____

Exp. Date: _____

Signature: _____

_____ Membership Only _____ Membership + Initiation Package

**Optional Initiation Package
For New Members Only**
1 - Back issue of *The Restorer*
1 - MAFCA Lapel Pin
1 - MAFCA Decal
1 - Name Badge
Only \$10 extra



Return this form and payment to:
MAFCA

250 South Cypress Street • La Habra, CA 90631-5515

Source: MAFCA Web Site
2009 Membership Form



Lexington, Ky., to host more than 800 Model 'A' Fords June 24-28, 2013

Lexington, Ky., will be the site of the 2013 National Meet of the Model 'A' Restorers Club, an international group that supports the preservation and enjoyment of the Model 'A' Ford, which was manufactured from 1928-31. The Central Kentucky chapter of the Model 'A' Restorers Club will host the event June 24-28. The year 2013 will be the 85th anniversary of the first Model 'A' Ford and the 100th anniversary of the Ford - Louisville Assembly Plant.

Events will include:

- Daily Model 'A' driving tours visiting such sites as Keeneland, Shakertown, the Kentucky Horse Park, distilleries, horse farms, museums, shops, wineries, restaurants, and more;
- Seminars on vehicle restoration and maintenance;
- Fine point judging of some of the most original Model 'A' Fords in the nation;
- A fashion show of 1920s-'30s clothing;
- A swap meet of antique auto parts and period clothing and jewelry.

The Central Kentucky Model 'A' Restorers Club consists of more than 80 member-families from central and eastern Kentucky and beyond. The group holds monthly Model 'A' tours and other events.

HOST HOTEL: Hyatt Regency Lexington - 401 West High Street - Lexington, KY

Call (800) 233-1234 after June 23, 2012

Be sure to give this code **MDLA** to get the Meet Rate



July 14 - 18, 2014

Sponsored by The Gallopin Gertie Model A Club. On the Western Washington Fairgrounds in Puyallup, WA. Puyallup, Washington (pronounced Pew al up), one of Washington State's oldest cities, is located approximately eight miles east of Tacoma in the Puyallup River valley.

Sitting at the foot of Mt. Rainier, the area boasts spectacular views while still providing a modern-day urban atmosphere inside the city.

29TH ANNUAL

Hill and Valley Antique Auto and Americana Show

Saturday, September 15, 2012
Baer Park in Cross Plains, Wisconsin

One hour tour through our hills and valleys
Antique and classic cars and trucks
Antique tractors and gas engines
Horse-drawn vehicles

Pancake breakfast 6:45 - 10:15 am
Free sweet corn at the Steam Engine
Food concessions 10:30am - 3:30pm

Americana displays:
Blacksmithing
Wheelwright
Telegraphy Demo
Sauerkrauting
Spinning
Quilting
Arts & crafts show



FREE ADMISSION • FUN FOR ALL AGES!

CALL FOR ADDITIONAL INFO

Don Chandler, H: 608/798-3040, C: 608/513-8254, lrchandler@tds.net
or John Riley, 608/798-0045 (cwessing2)
For local lodging see: <http://www.visitmidsouth.com/lodging.php>



2013 MAFCA NATIONAL TOUR
BLUE RIDGE PARKWAY
MAY 6-10

Welcome to the official website of the 2013 MAFCA National Tour down the Blue Ridge Parkway. Covering approximately 470 miles from the north entrance, Rockfish Gap, VA, to the southern tip of the parkway near Cherokee, NC. The Blue Ridge Parkway is accepted as one of the most beautiful drives in America and is perfect for a Model A. Commercial traffic is prohibited and the speed limit the entire parkway is a comfortable 45MPH or less. Over the course of the tour we will stop at many scenic and historic points of interest which will surely take your breath away. Each night you can relax at a top of the line hotel and enjoy catered meals and other forms of entertainment while you rest up and reflect on the days activities. Come be a part of what will surely be one of the most memorable trips that you and your A have ever taken.

<http://www.mafcablueridgetour.com/>

Patronize Our Advertisers

Templin's Old Time Auto, LLC

Model A Ford Parts New, Used, & Rebuild
1022 Mulberry St./County A • Lake Mills, WI
We offer mechanical repairs, specializing in Model A's

Mon/Wed
2:30 pm - 7:00 pm
Tues/Thur
4:30 pm - 7:00 pm
Sat
9:00 am - 4:00 pm
Fri - Closed
By Appointment Only

*Also Closed on
Sundays, Holidays
and Swap Meets*

www.oldtimeauto.net • Jeff Templin, Owner

Orders can be faxed or e-mailed in at anytime
(920) 648-5282 - Phone • (920) 648-5920 - Fax
jeff@oldtimeauto.net

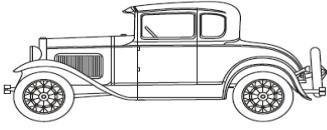
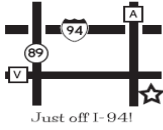

Antique Auto Repair & Mechanical Restoration Specializing in Model "A's"

Serving the Rockford, Chicago, Madison, Milwaukee Area

All Repairs Guaranteed



Tri-City Auto Service Inc.

(815) 638-2778

Email: tri-cityauto@sbcglobal.net

Complete Alternator & Starter Rebuilding
Auto, Truck, Industrial & Farm Vehicles

SUPERIOR AUTOMOTIVE ELECTRIC (608) 365-5201

Owners:
Edward Trapp
Bonnie Trapp

3219 S. Riverside Dr.
(Hwy 51)
Beloit, WI 53511



LaShelle Engine Restoration

1802 Crossroads Lane
Freeport, IL 61032

*Antique - Classic - Industrial
Model A Ford Rebabbing & Align Boring*

Jim LaShelle - Owner

Cell: 815-821-3546 • Home: 815-233-4803

FOR SALE: 1930 Model A Coupe. Contact Bob Poggensee 815-501-1981

TO TRADE: 1930 Model A radiator (not plugged; holds water) for set of 4 shocks with arms and links; workable or re-buildable.

Contact Dan Campbell for details 847-565-9763 or camclan10@yahoo.com

FOR SALE: 1988 Ford Thunderbird; 41,000 miles; custom built; excellent cond., \$5000. Contact Jerry Carpenter for details 815-232-2308

WANTED: "Gulf Oil" items (oil cans, signs, etc.) for my vintage gas station. Contact Wayne Henson 815-645-8695 or battgcmdr@aol.com

ROCKFORD, IL 61110

P.O. Box 4001

